

Accuphase

STEREO POWER AMPLIFIER

P-7500

- Large output 300 W / 8 ohms, 600 W / 4 ohms, 900 W / 2 ohms
- 10-parallel push-pull output stage power transistors
- Instrumentation amplifier principle
- Current feedback amplification circuits
- Balanced Remote Sensing
- MCS+ circuit
- High damping factor of 1,000
- Speaker output protection
- Highly responsive large-scale power meters
- Support for bi-amping and bridged mode connection





High output stereo power amplifier bursting with musical expression

The P-750 is our flagship model Class AB stereo power amplifier that provides supreme driving performance. The power amplification stage uses a 10-parallel push-pull power transistor architecture, providing a rated output power of 300 W / 8 ohms that vastly exceeds that of conventional models. Boasting an impressive signal-to-noise ratio of 130 dB and a damping factor of 1,000, it can effortlessly drive massive speakers and create musical recreations overflowing with energy. The P-750 brings out the best of any speaker, allowing you to enjoy never-before experienced soundscapes.

Groundbreaking technology

The P-750 power amplifier uses state-of-the-art circuitry and the highest quality materials to achieve a perfect blend of refined responsiveness and groundbreaking technology.

Ample output power

The 10-parallel push-pull power transistor output stage produces linear output power of 300 W into 8 ohms or 600 W into 4 ohms, and a whopping 900 W into 2 ohms of maximum output power.

Ultra low noise performance

Ideal gain distribution and other sophisticated techniques improve noise level suppression by 11% over the previous model.

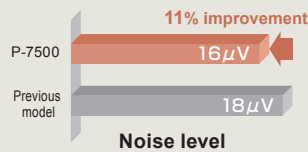

High damping factor

With a damping factor of 1,000, the speakers can be driven with full control over the counter-electromotive forces to get the most out of your speakers.

Balanced remote sensing

Balanced remote sensing improves damping factor by feeding back the GND at the same time as signal output from the speaker terminals.

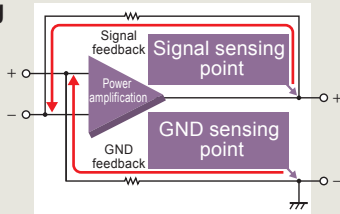

MCS+ (Multiple Circuit Summing-up) principle

By placing the voltage amplification stage in a two-parallel circuit layout, the MCS+ circuit theoretically reduces the noise floor by 30%.

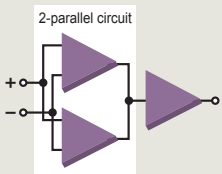

MCS+ circuitry

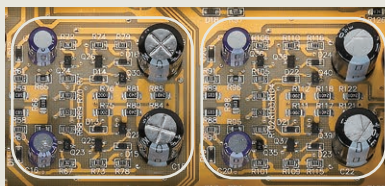

2-parallel circuit layout of MCS+ principle

Instrumentation amplifier

With balanced circuits in the signal input section, the amplification stage is comprised entirely of an instrumentation amplifier principle that equalizes input impedance on the + and - sides, for excellent external noise suppression, and providing optimal circuitry for this high-end audio amplifier.

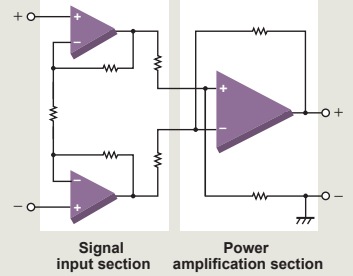

Ideal gain distribution

Noise level suppression has been dramatically improved by assigning a high gain (12.6x) in the signal input section with excellent noise figure results.

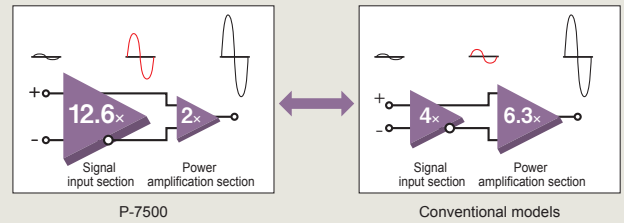

Gain distribution comparison

Current feedback amplification topology

The current feedback amplification circuit offers excellent phase characteristics in the high-frequency range with almost no impact on the frequency response even when gain is switched, resulting in natural and dynamic driving of the speakers.

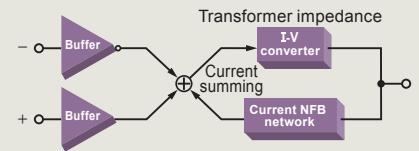

Three-stage Darlington configuration

The three-stage Darlington configuration that drives the final output stage by a two-stage drive circuit minimizes any negative influence on the output stage from the counter-electromotive forces of the speakers.

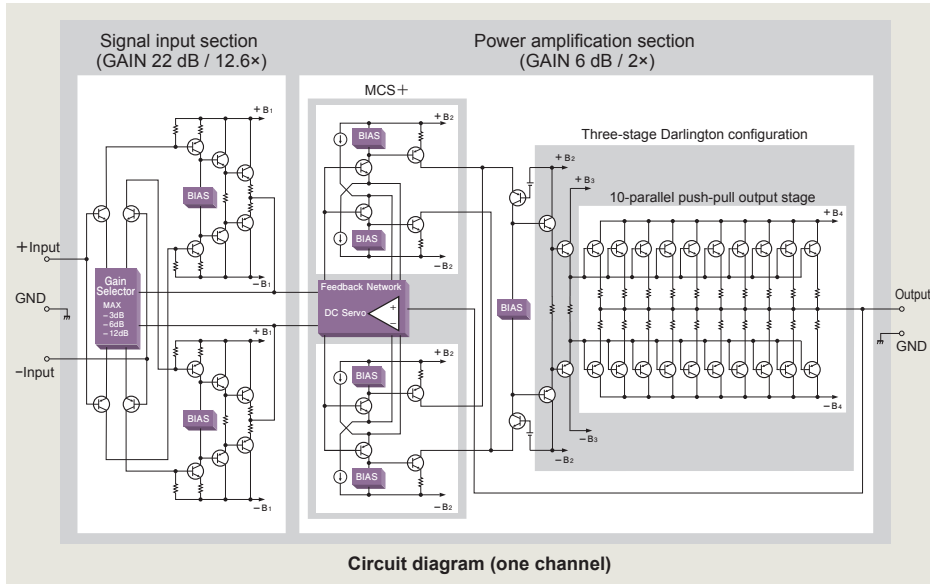

Circuit diagram (one channel)



L ch power amplification section

Filtering capacitors

R ch power amplification section

Advanced features

- 300 W / 8 ohms, 600 W / 4 ohms, 900 W / 2 ohms large output power
- 10-parallel push-pull power transistor output stage
- Instrumentation amplifier principle
- Current feedback amplification topology
- Balanced remote sensing
- MCS+ circuitry
- Three-stage Darlington configuration
- Meter display switching①
- LINE / BALANCED input switching②
- 4-step gain control③
- Polarity switching of balanced input connectors④
- Support for bi-amping and bridged modes⑤
- Ideal gain distribution in the signal input section⑥
- Speaker output protection with short-circuit detection⑦
- Large speaker terminals connected directly to protection circuitry⑧
- Edgewise coils improve damping factor⑨
- Highly reliable MOS-FET switches with no mechanical connections⑩
- Large, high-efficiency toroidal transformer⑪
- High-capacity 60,000 μF filtering capacitors⑫
- Aluminum hairline finish top plate⑬
- Large, hi-sensitivity -50 to $+3$ dB power meters⑭
- High-carbon cast iron insulator feet with superior damping characteristics⑮
- Power amplification section with a large heat sink⑯



① Meter display selector



② Input selector button ③ Gain selector

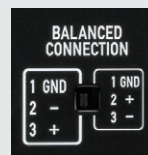

④ Balanced input polarity selector



⑤ Operation selector

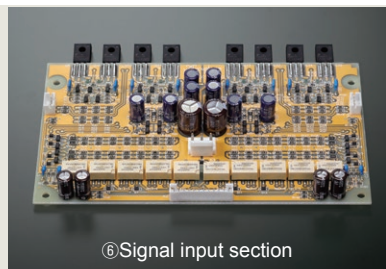

⑥ Signal input section



⑦ Protection circuitry



⑧ Speaker terminals



⑨ Edgewise coil



⑩ MOS-FET switches



⑪ Toroidal transformer



⑫ Filtering capacitors



⑬ Top plate



⑭ Power meter



⑮ Insulator feet

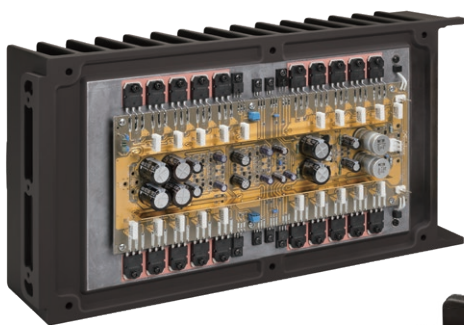

⑯ Power amplification section



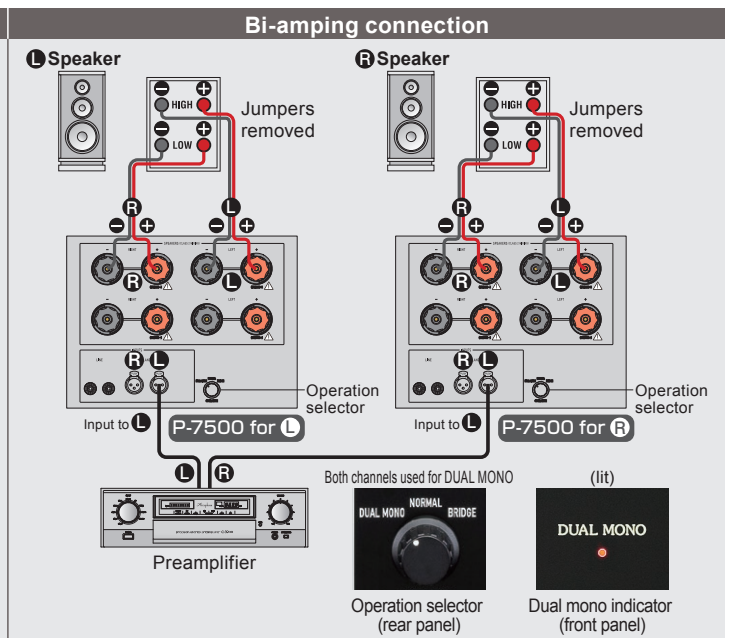
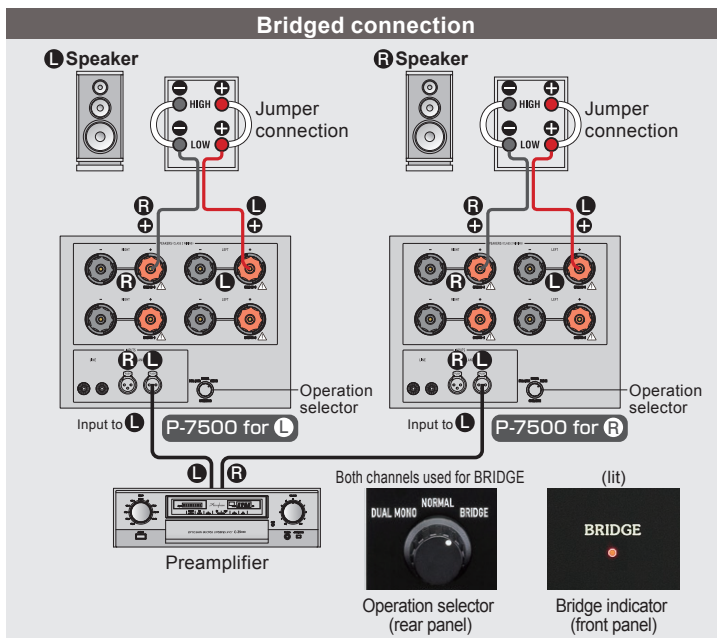

Front Panel

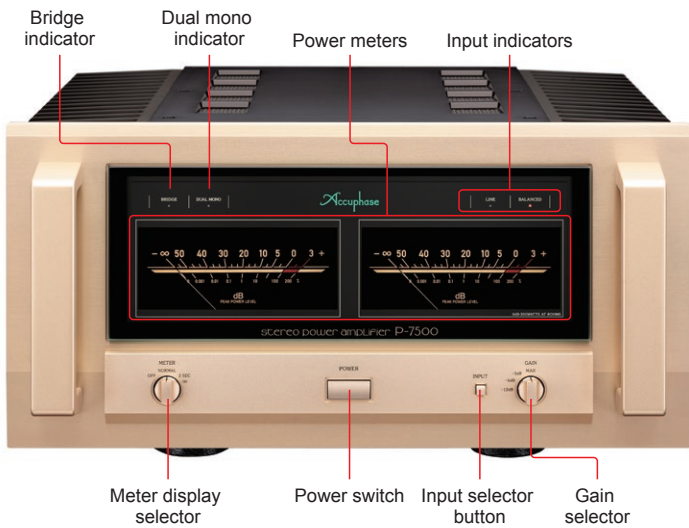

Rear Panel

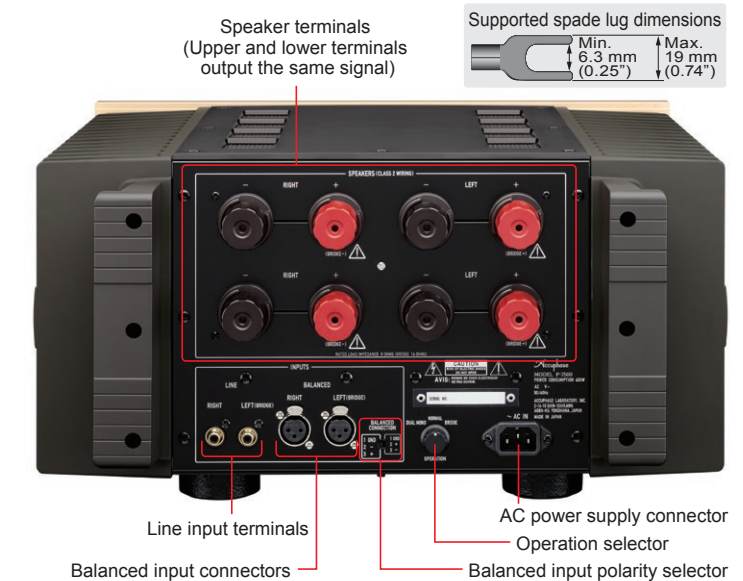

P-7500 Guaranteed Specifications

Rated Output (20 – 20,000 Hz, 0.05%)	Load	8 ohms	4 ohms	2 ohms
	Normal / bi-amping connection		300 W	600 W*1
	Bridged connection	1200 W*1	1800 W*1	—
Total Harmonic Distortion (20 – 20,000 Hz)	Normal / bi-amping connection	2 ohms	0.05%	
	Bridged connection	4 to 16 ohms	0.03%	0.05%
Intermodulation Distortion		0.01%		
Frequency Response	At rated output	20 – 20,000 Hz (+0, –0.2 dB)		
	At 1 W output	0.5 – 160,000 Hz (+0, –3.0 dB)		
Damping Factor	Normal / bi-amping connection	1,000 or greater		
Input Impedance	BALANCED / LINE input	40 kilohms / 20 kilohms		
Input Sensitivity	Output	At rated output	At 1 W output	
	Normal / bi-amping connection	1.95 V	0.11 V	
Bridged connection	3.90 V	0.11 V		
Signal-to-Noise Ratio (A-weighted, input shorted)	Gain Switch at MAX / at –12 dB	130 dB / 135 dB		

Gain	Gain switch	MAX	–3 dB	–6 dB	–12 dB
	Normal / bi-amping / bridged connection	28 dB	25 dB	22 dB	16 dB
Power Meters	Format	Logarithmic scale, with illumination off switch			
	Display range	–∞ to +3 dB			
	Peak hold time	3 sec. / ∞ switchable			
Power Requirements	During bridged connection	Displays same value for left and right			
		120/220/230 V AC, 50/60 Hz (Voltage as indicated on rear panel)			
Power Consumption	Idle	142 W			
	In accordance with IEC 62368-1	450 W			
	Stand-by	0.3 W			
Maximum Dimensions	Width 465 mm (18.3") × Height 238 mm (9.4") × Depth 515 mm (20.3")				
Mass	Net	49.0 kg (108.1 lbs)			
	In shipping carton	58 kg (128 lbs)			

● "Normal connection" indicates standard stereo operation.

*1: Limited to music signals

Supplied accessories

- AC power cord

Remarks

★ This product is available in versions for 120/220/230 V AC. Make sure that the voltage shown on the rear panel matches the AC line voltage in your area.

★ The 230 V version has an Eco Mode that switches power off after 120 minutes of inactivity.

★ The shape of the plug of the supplied AC power cord depends on the voltage rating and destination country.



ACCUPHASE LABORATORY, INC.

● The specifications and appearance of this product are subject to change without notice.

<https://www.accuphase.com>

C2204Y 850-2229-00 (B1) PRINTED IN JAPAN